

FEATURES

- Single Supply Operation : 2V to 36V
- Dual Supply Operation : $\pm 1V$ to $\pm 18V$
- Allow Comparison of Voltages Near Ground Potential
- Low Current Drain $800\mu A$ Typ
- Compatible with all Forms of Logic
- Low Input Bias Current $25nA$ Typ
- Low Input Offset Current $\pm 5nA$ Typ
- Low Offset Voltage $\pm 1mV$ Typ

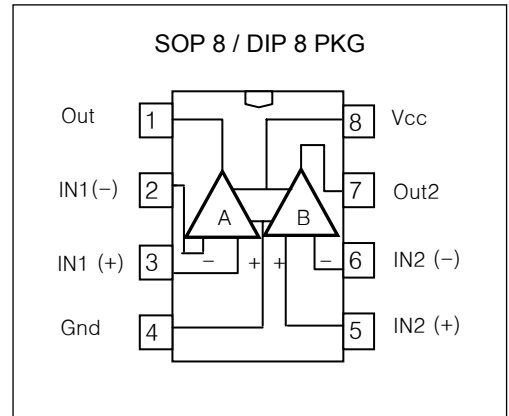

ORDERING INFORMATION

Device	Package
LM393D	8 SOP
LM393N	8 DIP

DESCRIPTION

The LM393 series consists of two independent precision voltage comparators with an offset voltage specification as low as $2.0mV$ max. for two comparators which were designed specifically to operate from a single power supply over a wide range of voltages. Operation from split power supplies is also possible and the low power supply current drain is independent of the magnitude of the power supply voltage.

These comparators also have a unique characteristic in that the input common-mode voltage range includes ground, even though operated from a single power supply voltage.

The LM393 series was designed to directly interface with TTL and CMOS. When operated from both plus and minus power supplies, the LM393 series will directly interface with MOS logic where their low power drain is a distinct advantage over standard comparators.

EQUIVALENT CIRCUIT

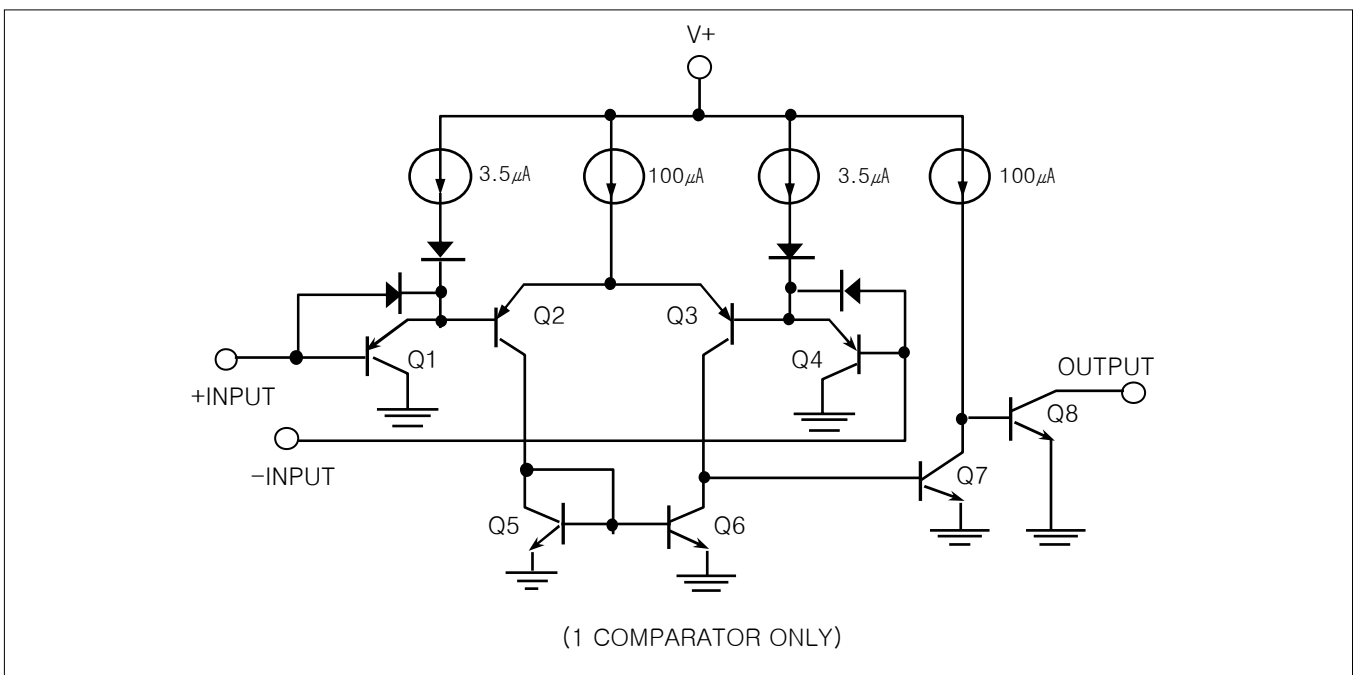

ABSOLUTE MAXIMUM RATINGS

CHARACTERISTIC	SYMBOL	VALUE	UNIT
Power Supply Voltage	V_{CC}	± 18 or 32	V
Differential Input Voltage	$V_{I(DIFF)}$	32	V
Input Voltage	V_I	-0.3 to +32	V
Output Short Circuit to GND		Continuous	
Power Dissipation	P_D	570	mW
Operating Temperature Range	T_{OPR}	0~+70	°C
Storage Temperature Range	T_{STG}	-65 to +150	°C

Electrical characteristics at specified free-air temperature, $V_{CC}=5V$ (unless otherwise noted)

PARAMETER	TEST CONDITIONS*	LM393			UNIT	
		MIN	TYP	MAX		
V_{IO} Input Offset Voltage	$V_{CC}=5V$ to 30V $V_{IC}=V_{ICRMIN}$, $V_O=1.4V$	25 °C	2	5	mV	
		Full Range		9		
I_{IO} Input Offset Current	$V_O=1.4V$	25 °C	5	50	nA	
		Full Range		150		
I_{IB} Input Bias Current	$V_O=1.4V$	25 °C	-25	-250	nA	
		Full Range		-400		
V_{ICR} Common-Mode Input Voltage Range**		25 °C	0to $V_{CC}-1.5$		V	
		Full Range	0to $V_{CC}-2$			
A_{VD} Large-Signal Differential Voltage Amplification	$V_{CC}=15V$, $V_O=1.4V$ to 11.4V, $R_L \geq 15k\Omega$ to V_{CC}	25 °C	50	200	V/mV	
I_{OH} High-Level Output Current	$V_{OH}=5V$, $V_{ID}=1V$ $V_{OH}=30V$, $V_{ID}=1V$	25 °C		0.1	50	nA
		Full Range			1	μA
V_{OL} Low-Level Output Voltage	$I_{OL}=4mA$, $V_{ID}=-1V$	25 °C		150	400	mV
		Full Range			700	
I_{OL} Low-Level Output Current	$V_{OL}=1.5V$, $V_{ID}=-1V$	25 °C	6		mA	
I_{CC} Supply Current	$R_L=\infty$	$V_{CC}=5V$		0.8	1	mA
		$V_{CC}=30V$	Full Range		2.5	

* Full range (MIN to MAX), for LM393 is 0°C to 70°C. All characteristics are measured with zero common-mode input voltage unless otherwise specified.

** The voltage at either input or common-mode should not be allowed to go negative by more than 0.3V.

The upper end of the common-mode voltage range is $V_{CC} - 1.5V$, but either or both inputs can go to 30V without damage.

Switching characteristics, $V_{CC}=5V$, $T_A=25^\circ C$

PARAMETER	TEST CONDITION	LM393			UNIT
		MIN	TYP	MAX	
Response Time	R_L Connected to 5V Through 5.1k Ω , $C_L=15pF$ *(See Note 1)	100-mV Input Step with 5-mV Overdrive		1.3	μs
		TTL-Level Input Step		0.3	

* C_L includes probe and jig capacitance.

Note 1 : The response time specified is the interval between the input step function and the instant when the output crosses 1.4V.

TYPICAL PERFORMANCE CHARACTERISTICS

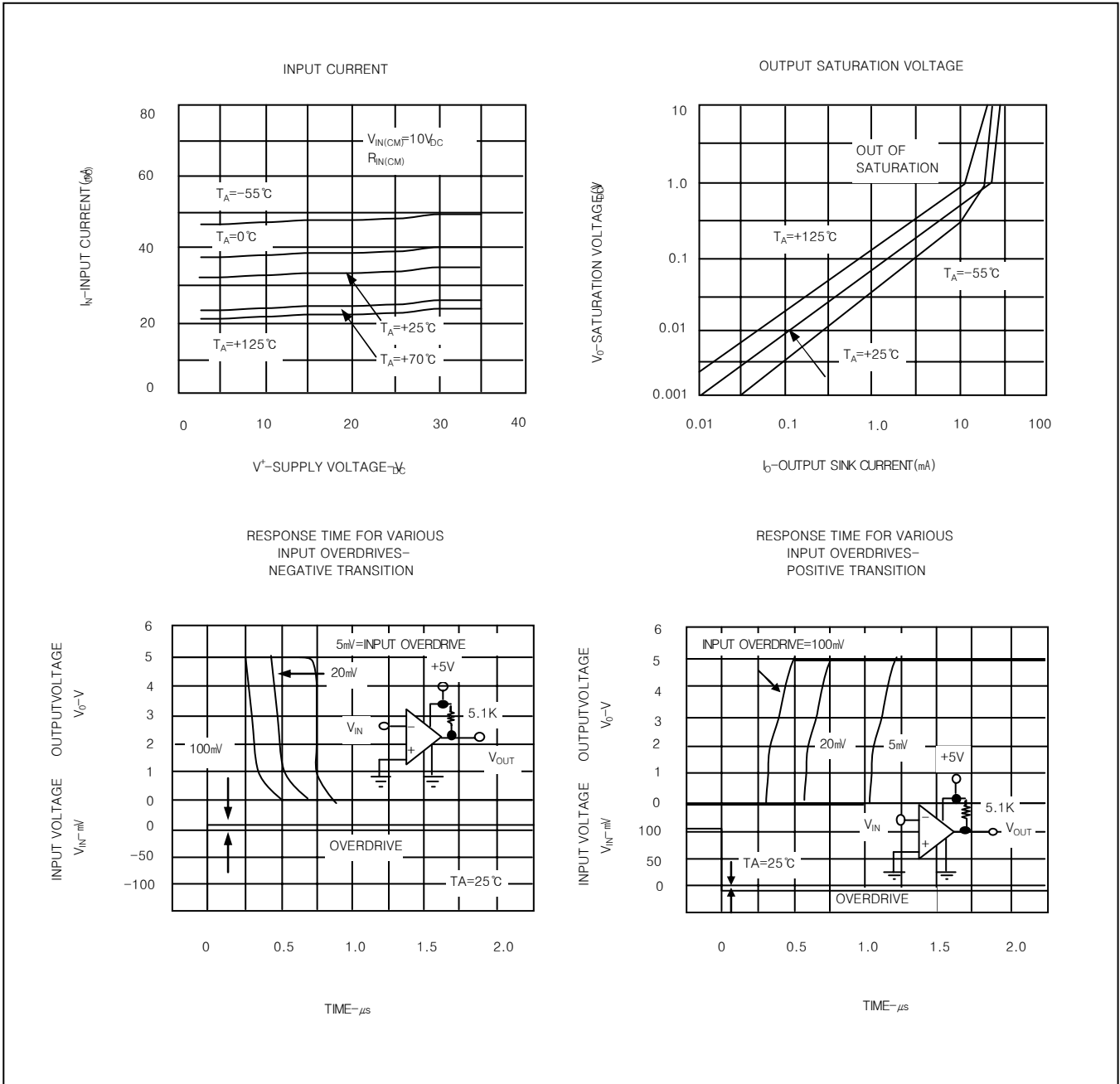

TYPICAL APPLICATIONS

